

Prénom :

Mon fichier de calcul

Le travail se réalise en autonomie.

Je peux le prendre quand j'ai fini
un travail, quand j'ai un peu de
temps.

Je le complète au crayon de papier ; les consignes ne sont pas écrites : je dois trouver seul ce qu'il faut faire.

Chaque jour, je dois avoir réalisé (*au minimum*) 4 exercices au choix.

7	-		+	4	=	8
-		+		+		+
2	x	1	x		=	8
+		+		x		+
	+		+		=	8
=		=		=		=
8	+	8	+	8	=	24

Date :

				8	<input type="radio"/>
				14	<input type="radio"/>
				8	<input type="radio"/>
				15	<input type="radio"/>
					<input type="radio"/>
					<input type="radio"/>

Date :

$7 \times \square \rightarrow \square$
 $\square \times 7 \rightarrow 56$
 $\square + 28 \rightarrow \square$

$\square \times 6 \rightarrow 12$
 $6 \times \square \rightarrow \square$
 $\square + \square \rightarrow 30$

Date :

23

3	6	7
	7	

	7		

22

2	3	6	7
4	7	7	8
6	4	5	7
5	9	7	2

19

	7	

		7

25

Date :

80 g

100 g

70 g

Date :

40

$36 + 4$

$80 : 2$

2×20

19

20

2	20	90	48 - 8	2		
17	23	50	50	56	20	4
20	20	10	20	16	20	10
26	90	120	70	30	10	4
14	50	3	20	14	26	10
80	2	16	24	26	14	30

Date :

+ $2+3=5$ $7-2=5$

- $1+4=5$

1	3	2
8	4	2

3	10	4
3	2	4

2	10	1
7	6	3

11	3	4
4	5	2

7	8	4
3	2	2

12	8	3
7	2	3

4	5	3
8	1	6

3	11	4
4	14	7

Date :

○	5	1		
x	3	5		
<hr/>				
	3	2	5	○
1	○	5	○	
<hr/>				
2	2	○	8	○

Date :

+- $14 - 12 + 6$ **+-** $13 - 9 + 7$

8 → _____ **11** → _____

+- $12 - 14 + 13$ **+-** $16 - 2 + 12$

13 → _____ **6** → _____

Date :

27

22

6	

5	4	8	6
3	9	6	3
9	7	2	8
8	9	6	5

24

9	

25

Date :

6	+		+	2	=	13
+		+		+		-
	+		-	6	=	4
+		+		+		+
	+	1	+		=	9
=		=		=		=
18	+		-	10	=	

Date :

				○
				15
				19
				○
				12
				○
○	20	30	○	

Date :

30

7		8	6	6
	3	8	5	5
		4	8	7
5	7		7	
7	8			7

Date :

34

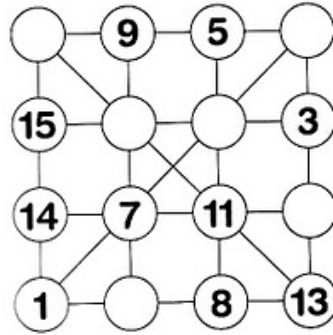

34

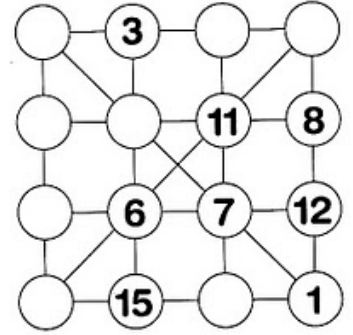

Date :

+

1	3	4
9	-	5
7	-	3

7	3	12
4	6	2

2	8	10
3	7	0

-

10	2	5
9	1	3

12	3	5
4	6	2

7	8	3
4	15	4

12	3	20
7	8	5

4	9	16
15	2	3

3	12	10
16	1	5

Date :

12

6
+

4 x 3

7

14 - 2

16

4

8

6

15

11

4

5

2

10

6

3

2

5

7

2

6

3

4

9

17

13

1

10

13

15

3

8

8

4

2

3

4

5

4

Date :

○

6

7

○

18

○

—

—

—

—

12

○

15

○

Date :

	+	4	+	2	=	9
+		+		+		
9	+		-	3	=	7
-		-		-		
	+	5	+		=	9
=		=		=		=
10		0		3	=	7

Date :

38

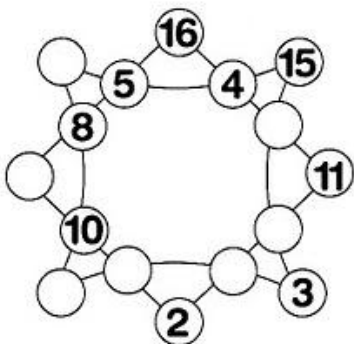

34

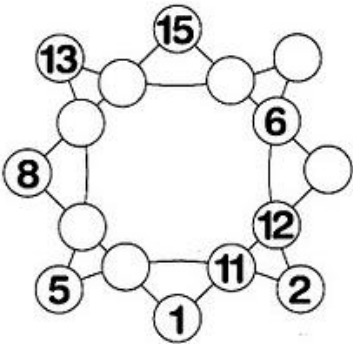

Date :

+

3	3	9
6	3	5

8	9	20
3	15	4

6	2	9
3	4	3

X

7	3	3
20	1	18

2	3	6
4	5	2

4	12	4
4	15	1

6	32	4
6	29	7

14	7	4
2	19	9

3	10	2
4	5	7

Date :

+ -

10 8 7

9 → _____

+ -

12 3 11

20 → _____

+ -

4 5 7

2 → _____

+ -

15 3 10

8 → _____

Date :

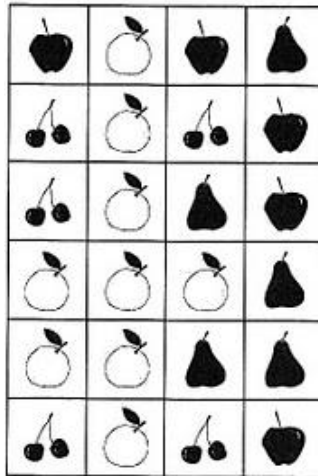

19

○

○

15

○

22



32 18 34 ○

Date :

+

8 ○ 5 ○ 2 = 42

-

8 ○ 5 ○ 2 = 15

X

8 ○ 5 ○ 2 = 1

8 ○ 5 ○ 2 = 11

8 ○ 5 ○ 2 = 38

8 ○ 5 ○ 2 = 26

Date :

26

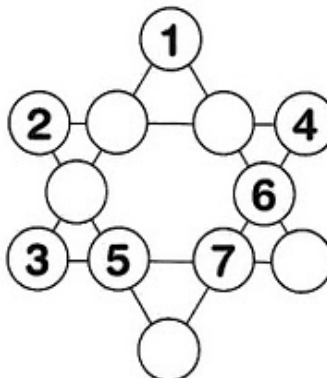

26

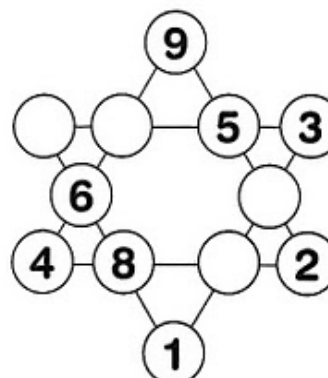

Date :

15

3	2	10	7	4	4	5
7	5	3	3	6	6	4
5	8	5	5	5	6	3
6	4	5	6	7	3	8
7	3	6	5	9	1	7
2	10	0	5	8	8	5
6	3	9	4	4	7	4

Date :

○	○	7	2
x		5	○
		8	1
		4	4
○	0	○	6
2	○	1	○
4	○	4	○

Date :

+

x

3×3	$4 + 5$	8 9 6	6 2 9
$6 + 3$	9	3 15 4	3 4 3
7 3 3	2 3 6	4 12 4	20 1 18
4 5 2	4 12 4	4 15 1	6 32 4
14 7 4	2 24 2	2 24 2	6 29 7
2 19 9	13 19 7	13 19 7	2 19 9

Date :

-6

x3

-10

x5

→	12	6	36	21	→	15	125	65	55
	36	18	24	30		5	25	15	35
	30	12	36	84		35	65	75	95
	24	72	30	90	→	45	85	65	325

Date :

17 + 12 =

- 19
- 29
- 39

19 + 23 =

- 32
- 42
- 52

51 + 22 =

- 83
- 73
- 63

18 + 18 =

- 16
- 26
- 36

28 + 12 =

- 20
- 30
- 40

32 + 17 =

- 29
- 39
- 49





























Date :

_____		_____		_____
_____		_____		_____
_____		_____		_____

Date :

5	+		+	2	=	15
x		+		+		+
	+		-	1	=	
-		-		x		-
	+	5	+		=	15
=		=		=		=
	-	15	+	15	=	15

Date :

				<input type="radio"/>	
				6	 _____
				7	 _____
				<input type="radio"/>	 _____
				18	 _____
				<input type="radio"/>	

12 15

Date :

+ 7 5 2 = **10**

- 7 5 2 = **14**

x 7 5 2 = **0**

7 5 2 = **4**

7 5 2 = **37**

7 5 2 = **70**

Date :

24

12	4 x 6	14	28 - 4	32
+	8	16	12	30
12	22	8		
10	4	20	12	6
4	12	6	16	18
34				
26	2	20	26	30
6	16			
16	8	4	6	8
2	8			
29	1	2	14	3
26	20			

Date :

7	x		→						
x		x		+					
	x	7	→	56					
56	+	63	→						
	x	7	→	63					
x		x		+					
8	x		→						
	+	63	→	135					

Date :

17 - 12 =	5	39 - 23 =	16
	15		26
	9		36
	18		39
51 - 23 =	38	38 - 19 =	29
	28		19
	16		35
28 - 12 =	26	32 - 17 =	25
	36		15

Date :